

Go-kart2

OWNER'S MANUAL



Kimroad Xintian Motorcycle Manufacture Co., Ltd.

www.kinroad.com

CONTENTS

	Page
1. Foreword	1
2. Warning & Safety Notes	2
3. Specification	4
4. PDI	8
5. Operation	10
6. Service Instructions	21
7. Repair	31
8. Periodical Check and Services	35
9. Wiring Diagram	36

FOREWORD

Sincere gratitude for your choice of our Kart. We will provide you with premium services

This Owner's Manual contains important safety and maintenance information. Read it carefully before you ride your new Kart. Failure to follow the warnings contained in this manual can result in INJURY or DEATH.

It is our sincere wish that you enjoy operating the Kart and getting fun from it. Should you have any problems please feel free to contact our local dealer in your area.

It is important that this manual remain with the vehicle when you sell it. The next owner will need this manual also. Keep it well because it's very important.

Perform this pre-ride inspection everyday before riding the kart. If not performed, serious damage to the kart or personal injury may result from it.

Do not attempt to start or operate this engine until completely familiar with the location and use of each control necessary to operate this kart. The operator must know how to stop this machine before starting and riding it.

The beginner should drive the kart in a large open area to avoid sharp turns, high speed, and rough ground.

WARNING & SAFETY NOTES

- Read this owner's manual carefully and make sure you understand it completely before driving this kart.
- Do not allow anyone under age 16 to drive this kart.
- This kart is designed and manufactured for off-road use only. Operation on public streets, roads or highways is illegal.
- Always wear an approved motorcycle helmet.
- Always wear the seat belt and have it adjusted properly
- Do not operate this kart at night.
- It's dangerous to drive on an unknown road.
- Keep a safe distance between your kart and other vehicles.
- Never consume alcohol or drugs before or while operating this kart which can weaken your capacity of control and result in injury or even death.
- The fuel supply should be checked before each time the kart is used.
- Gasoline should never be poured into the tank while the engine is hot or running. Spilled oil or gasoline should be wiped off prior to starting the engine.
- Never run your kart indoors. The exhaust from the engine contains a tasteless, odorless and poisonous gas called carbon monoxide.

WARNING & SAFETY NOTES

- Unusual noise or vibrations from your kart generally indicate loose or worn parts. The engine should be stopped before the problem is checked.
- The operator of the kart should never place his hands or other parts of his body near any moving part of the kart.

Failure to follow these instructions could endanger personal safety and/or property. Read and follow all the instructions in this Manual before attempting to operate your kart.

SPECIFICATIONS

DIMENSIONS

Overall Length	87.7" (2075mm)
Overall Width	48.6" (1235mm)
Overall Height	55.1" (1400mm)
Wheelbase	57" (1450mm)
Front Track	41.7" (1060mm)
Rear Track	39.4" (1000mm)
Ground Clearance	5.1" (130mm)

ENGINE

Type	Forced air-cooled 4 stroke
Engine capacity	150cc
Bore x Stroke	57.4x57.8
Displacement	149.5ml
Corrected Compression Ratio	9.2:1
Carburetor	PD25J
Output Power	7.4kw/7500rpm
Maximum Torque	9.5/5500Nm/r/min
Starting	Electric

SPECIFICATIONS

Ignition	CDI
Lubrication	Force & Splash
Transmission	Automatic CVT
Spark Plug	C7HSA(NGK)
Plug Gap	0.6-0.7mm
Fuel Brand	RQ-90(Leadless)
Lubricate Oil Brand	SAE10W-30

CAPACITIES

Load	1 rider or 90kg
Fuel Tank	7.0L
Engine Oil Capacity	850ml
Starting	<5s
Climbing	20°-25°

ELECTRICAL

Battery	12V 6.5Ah
---------	-----------

SPECIFICATIONS

Head Light-----12V15W
Tail light-----12V 10W/5W
Fuse-----10A

CHASSIS

Front Brake-----Hydraulic disc/left foot control
Rear Brake-----Hydraulic disc/left foot control
Front Tire-----19x7.0-8
Rear Tire-----18x9.5-8
Front Suspension-----Dual A-arm with 1.8"(45mm) of travel
Rear Suspension-----Spring over shock with 2.4"(60mm) of travel
Brake Track-----<7m@20miles/h
Top Speed-----30miles/h(or limited as customers require)

WEIGHT

Dry Weight-----155kg

SPECIFICATIONS

TIRE PRESSURE

Front-----98kPa/m² 1kgf/cm² 14.2 lbf/in²
Rear-----98kPa/m² 1kgf/cm² 14.2 lbf/in²

WARRANTY

Parts & Workmanship-----90 Days

1. Install RR. Shocks and tighten the nuts.
2. Install Ball Head, Tie Rod, tighten the Castle Nut and insert the cotter Pin.
3. Install Dust Seals, align the Ball Head Bolt, Knuckle Support to the square hole on the Lower A-Arm.
4. Install Flange Nut and tighten it (>65N.m)
5. Install FR. Tires and tighten the nuts.
6. Install RR. Tires, tighten the nuts, insert cotter Pin and put on the Rubber Cover.
7. Raise the Rollcage Bar as what picture shows
8. Install Rollcage Bar, RR., put on R-Washer.
9. Install Headset.
10. Install Steering Wheel and Steering Wheel Cover.
11. Fill the 90# Gas into gas tank and turn on the Petcock to start the engine.

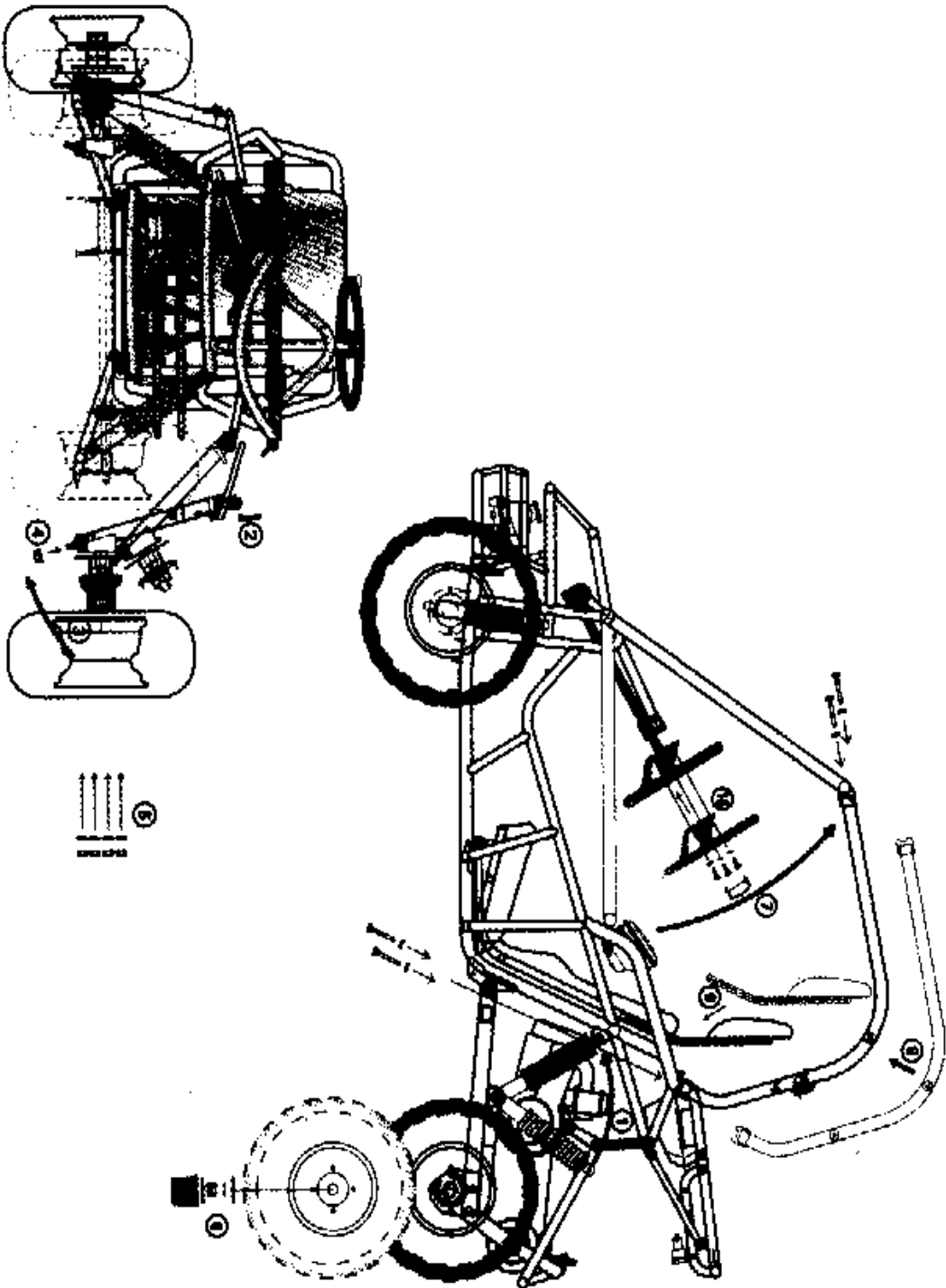

6

A. OPERATION CONTROLS

WARNING - Do not attempt to start or operate this engine until completely familiar with the location and use of each control necessary to operate this vehicle. The operator must know how to stop this machine before starting and riding it.

1. THROTTLE

The right foot pedal that increases and decreases the engine speed controls the throttle. As the engine speed is increased above idle, the clutch automatically engages and moves the vehicle forward. To disengage the clutch at any time, allow the throttle to return to the idle position. (See FIGURE 1)



WARNING

Each time prior to starting the engine, check the throttle assembly to ensure that when pedal is pushed all the way forward the assembly is working smoothly and returns to idle when released. Do not operate if pedal or engine throttle linkage fail to return to idle. If unable to correct the problem through lubrication, adjustment or replacement of worn parts, contact your dealer for assistance.

OPERATION

2. BRAKE

The brake is located on the left side of the kart (See Fig. 1). Applying pressure to the pedal draws the brake caliper around the brake pump at the rear wheel and slows or stops the kart.

3. ENGINE START

Insert the key into key-switch, turning the key with clockwise so that the engine would be start in 5 seconds, release the key when the engine start, the engine would come into warm up (2100RPM) idle speed, in 5 minutes the engine choke would close automatically and engage normal speed (1700RPM).

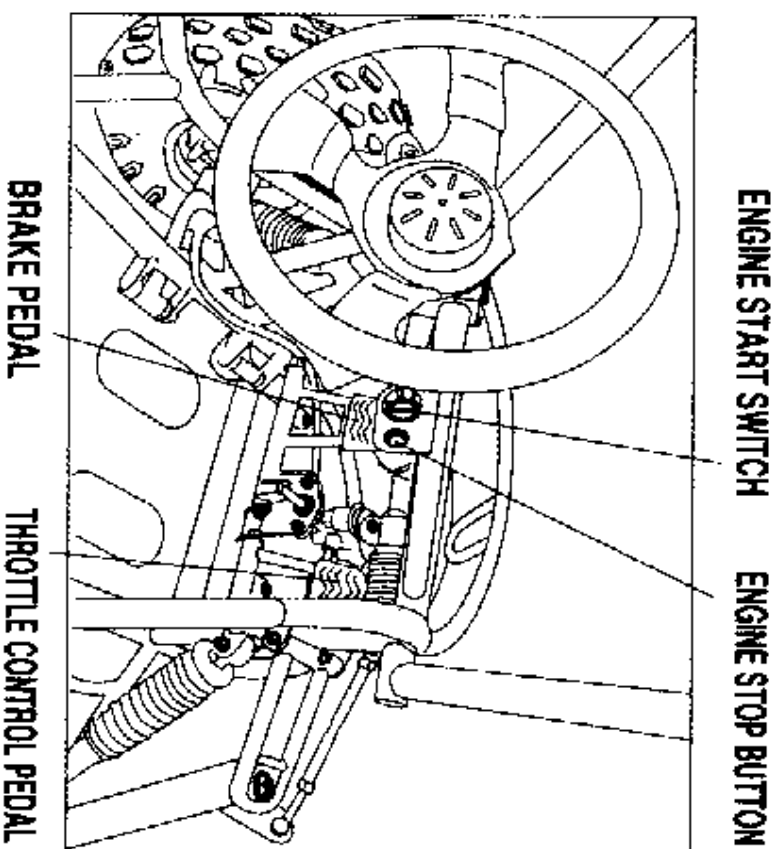

Figure 1

OPERATION

4. ENGINE STOP SWITCH

IMPORTANT - STOP SWITCH TEST

Before riding this vehicle, test the engine stop switch to assure that it is operating properly. With the engine running, move the stop switch to the "OFF" position.

B. PRE-RIDE INSPECTION

WARNING

Perform this pre-ride inspection everyday before riding vehicle. If not performed, serious damage to the vehicle or personal injury may result.

A. Engine oil level-add oil if required. Check for leaks.

OPERATION

- B. Fuel-level-add fuel as necessary. Do not overfill. Check for leaks.
- C. Brakes-perform Brake Test as outlined in OPERATION -OPERATING CONTROLS. Adjust if necessary.
- D. Tires-Check condition and pressure. The pressure on both Front & Rear is 98Kpa.
- E. Drive Chain-Check condition, tension, and lubricate as necessary.
- F. Throttle-Check for smooth operation. Assure throttle "snaps" back to idle.
- G. Stop Switch-Perform stops switch test. (See OPERATION-OPERATING CONTROLS). Repair as necessary.
- H. All nuts, bolts, and fasteners-Check wheels to see that all axle nuts and lug nuts are tightened properly. Check and tighten as necessary all other fasteners to specified condition.
- I. Guards-Ensure all protectiveguards are in place before operating this vehicle.
- J. Brakelight-check for proper operation.

OPERATION

- K. Wheels-check for tightness of wheel nuts and axle nuts; check that axle nuts are secured by cotter pins**
- L. Steering-check for free operation noting any unusual looseness in any area.**



CAUTION!

Always follow rules for safe operation and wear a helmet.

OPERATION

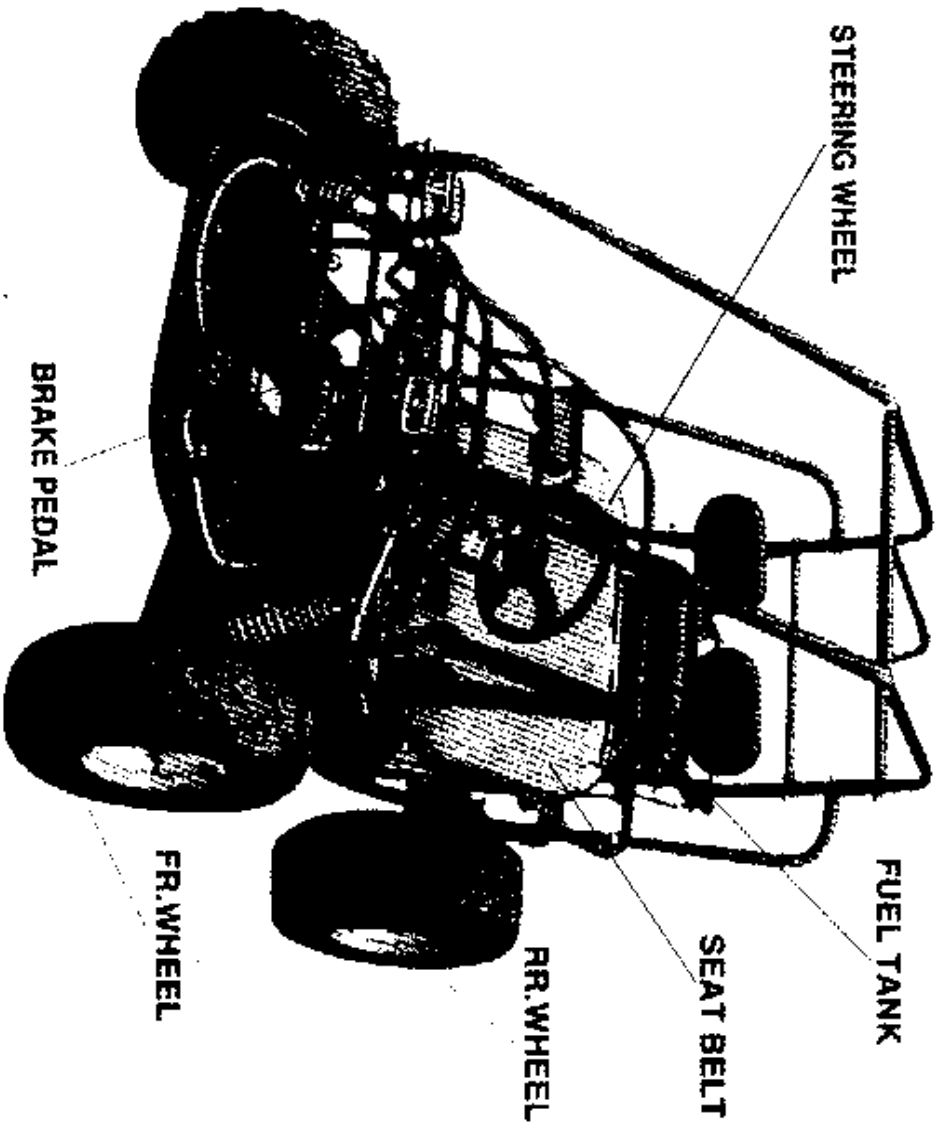

Figure 2

C. PASSENGERS

Some vehicles are designed and constructed to be used by the operator alone. Those vehicles have a single seat. The vehicle load limit and seating configuration does not safely permit the carrying of a passenger. With those vehicles the rule is OPERATOR ONLY-NO PASSENGER.

D. SEAT ADJUSTMENT

The seat must always be securely fastened in the position which best affords the operator control of the foot pedals, steering wheel, and the remote stop switch.

1. Pull seat adjustment handle upward to disengage seat slide.
2. Move seat to desired position

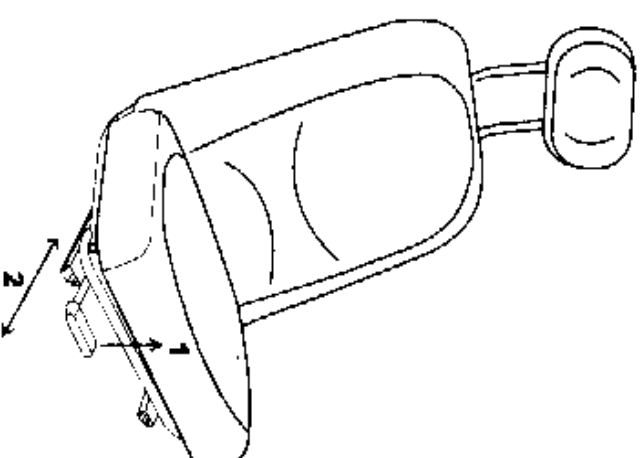

Figure 3

OPERATION

3. Be sure seat adjustment handle snaps back into place and that seat is locked into position.

CAUTION

Before attempting to adjust the seat ensures that engine of - vehicle is stopped.

WARNING

Never operate this vehicle when the provided seat is not securely fastened, to do so would result in a strong possibility of severe personal injury or loss of life.

E. REVERSE ADJUSTMENT

1. Press down the reverse lever to the "FW" position so that the units can move forward, pull back the lever to "BW" so that the units can move backward. (See Fig.4)

2. Adjusting Nut #1 on the top of the reverse cable can adjust the mesh status inside reverse gear box, 1/2 round as you adjust the rotation of Adjusting. Nut would be perfect. Do not fix too tighten nor too loose, adjust Adjusting Nut #1 and Adjusting Nut #2.

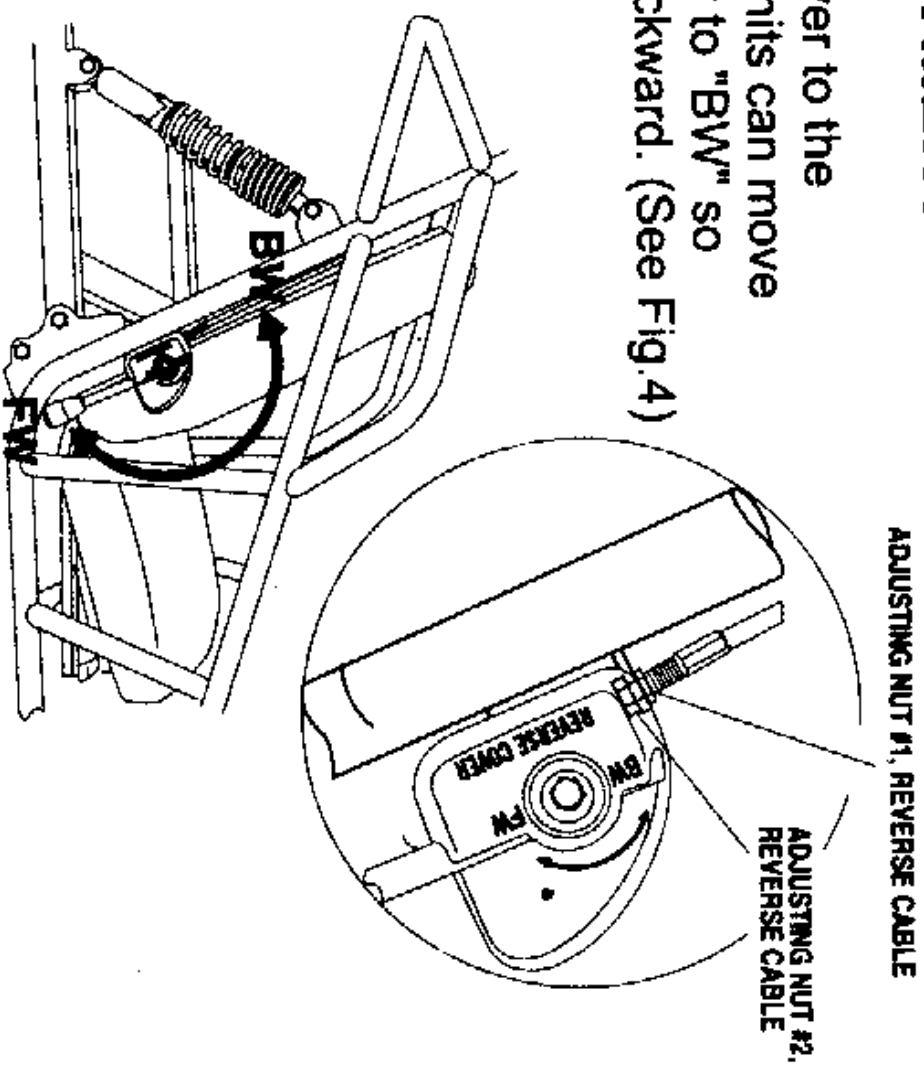

Figure 4

OPERATION

F. STARTING & OPERATING INSTRUCTIONS

1. Before starting the engine, be sure that the rider is seated properly in the kart and tighten the seatbelt.
2. Testing the kart in a widely place at the beginning to learn how to start, turns - and stop it.
3. Operate the kart slowly until you familiar with it.
4. Prohibit turning at high speed on rough terrain.
5. The turning diameter of this kart is small & agile, so the centrifugal force is too big under turning at high speed. It's easy for the beginners to drop out of the kart and roll over, so please turn slowly to prevent the kart from rolling over.
6. Prevent the kart roll over except above-mentioned, here's some other tips when you're turning the kart, hold the steering wheel tight and keep your.

heel on the ramp of the main board when turning. (See Fig.5) Keep your leg rely on the bush guard, you can feel the kart is stable because of the gravity is adjusted and won't roll over.

Figure 5

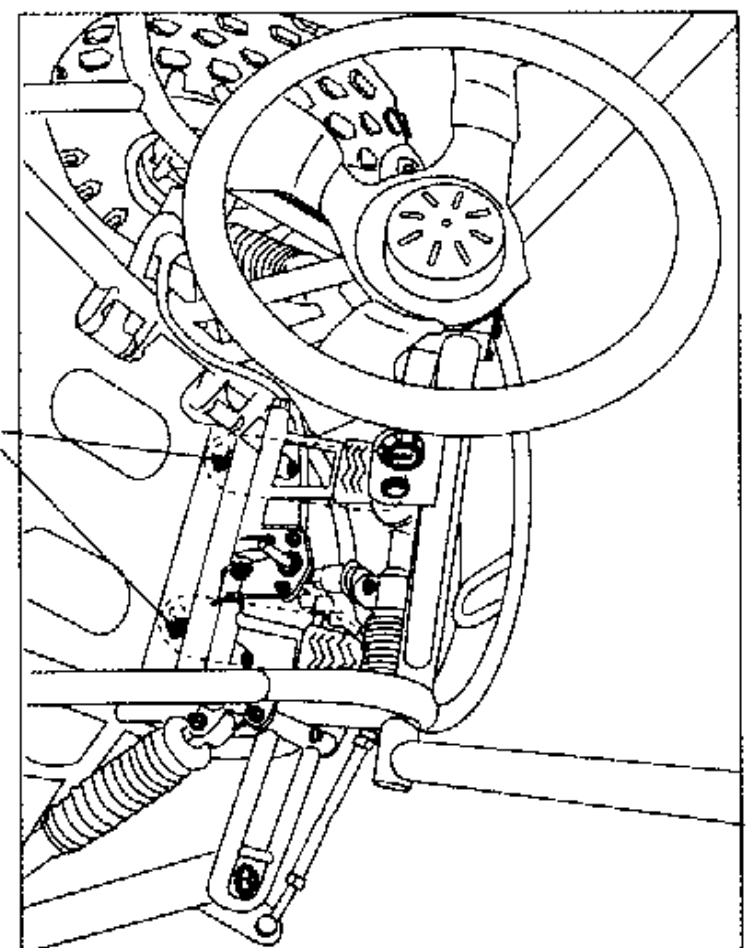

POSITION FOR HEEL

SERVICE INSTRUCTIONS

A. CARBURETOR ADJUSTMENT

1. SERVICE AIR CLEANER

Service pre-cleaner every 100 hours

NOTE: service more often under dusty conditions.

1. Remove cleaner cover
2. Remove air cleaner element 2,3 (See Fig.6)

TO SERVICE-PRE-CLEANER

1. Fill the non-flammable cleaning agent into a basin and dip the element in it.
2. Dry it after cleaning it, dip it into the

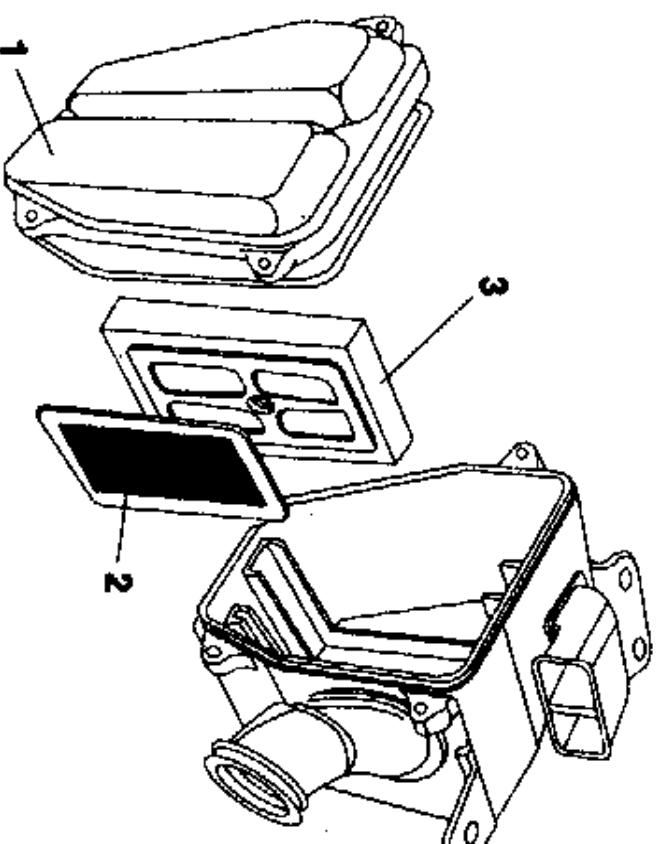

Figure 6

SERVICE INSTRUCTIONS

engine oil specified by the manufacture, and dry again.

2. ENGINE LUBRICATION

You must change the oil in the crankcase after the first 5 hours of operating of your new engine, (See Fig.7) and after 50 hours of use thereafter. That will insure proper lubrication of internal parts and prevent costly repairs due to excessive wear.

WARNING

Disconnect spark plug wire and place wire where it cannot make contact with the spark plug before changing oil.

SERVICE INSTRUCTIONS

- a.** Remove fill plug located on rear side of engine base. Tip kart backwards slightly, by blocking up the front end and drain oil into suitable container.
- b.** Replace fill plug and tighten securely. Place kart in a level position.
- c.** Refill crankcase (approximately 1 1/4 pint) to top of filler neck with SAE 10W40 oil. Use same grade of oil as used originally.
- d.** Check oil level before each use of kart or after each 10 hours of operation. Add oil to bring up to proper level. Do not mix various grades of oil.

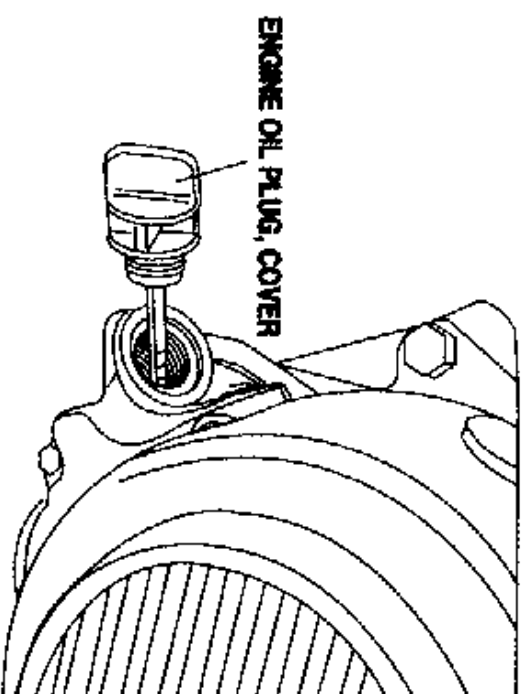

Figure 7

SERVICE INSTRUCTIONS

3. SPARK PLUG

- a.** Remove the spark plug and inspect it each time you change the oil. (Use a spark plug wrench)

The electrodes should be kept clean and free of carbon. The presence of carbon or excess oil will greatly deter proper engine performance. If possible, check the spark plug gap (area between electrodes) using a wire feeler gauge. This specification is 0.025"~0.030".

- b.** Before installing spark plug coat threads lightly with graphite grease if possible, to ensure easy removal next time the spark plug needs inspection.

- c.** It is advisable to replace the spark plug at least once a year to insure easy starting and good engine performance.

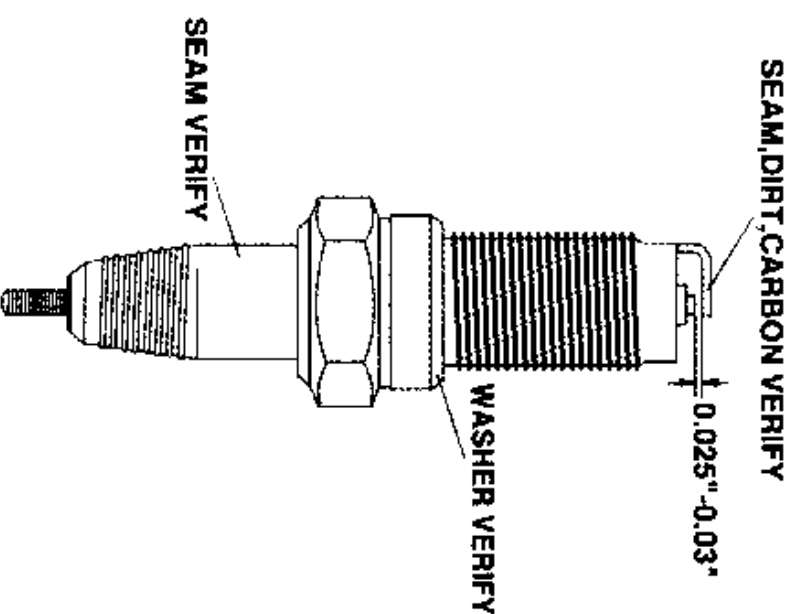

Figure 8

SERVICE INSTRUCTIONS

4. CARBURETOR ADJUSTMENT

Never make unnecessary adjustments. The factory recommended settings are correct for most applications. It's not necessary to disassemble the screw unless the carburetor needs to be replaced. Prepare a 50r/w tachometer before adjustment.

1. Warm up the engine (5~10min)
2. Tighten the screw gentle, 2 3/8 turns counter clockwise.
3. Connect the tachometer, adjust the throttle to limit the idle speed, the standard value is (1700±100) r/min
4. Turn the screw counter clockwise slowly and observe the rotate speed of the engine, stop adjusting as the rotate speed reaches the top speed.
5. Adjust the screw and adjust the idle speed to an ideal value.
6. Repeat step 4&5 until the rotate speed of engine stable.

SERVICE INSTRUCTIONS

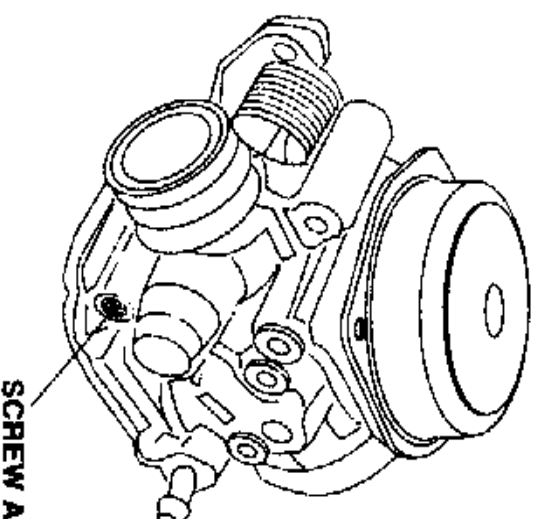
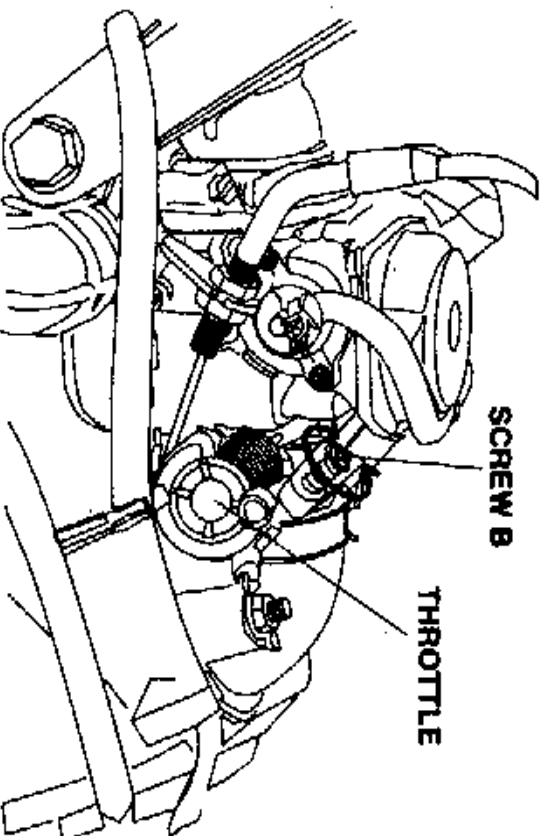

Figure 9

5. CLEANING INSTRUCTIONS

Keep your kart clean. With a clean rag, wipe off dirt and oil from around controls. Wipe off all spilled fuel and oil. Keep the engine clean of foreign matter and be sure to permit proper air circulations.

B. KART LUBRICATION

Every 90 days of use lubricate with several drops of oil in the specific point.

SERVICE INSTRUCTIONS

C. CHAIN LUBRICATION

For the best chain life, it should be lubricated with a graphite type lubricant such as the spray-on type. (See Fig. 10)

D. CHAIN ADJUSTMENT

After the first two hours of operation, check the chain adjustment, and readjust if it has more than 1/2" flex.

1. Loose Nut 1
2. Adjust Nut 2 (Upward turning would be loose and downward would be tighten)
3. Tighten Nut 1, verify if the chain loose or tighten enough and repeat the steps above-mentioned until it's good enough.

SERVICE INSTRUCTIONS

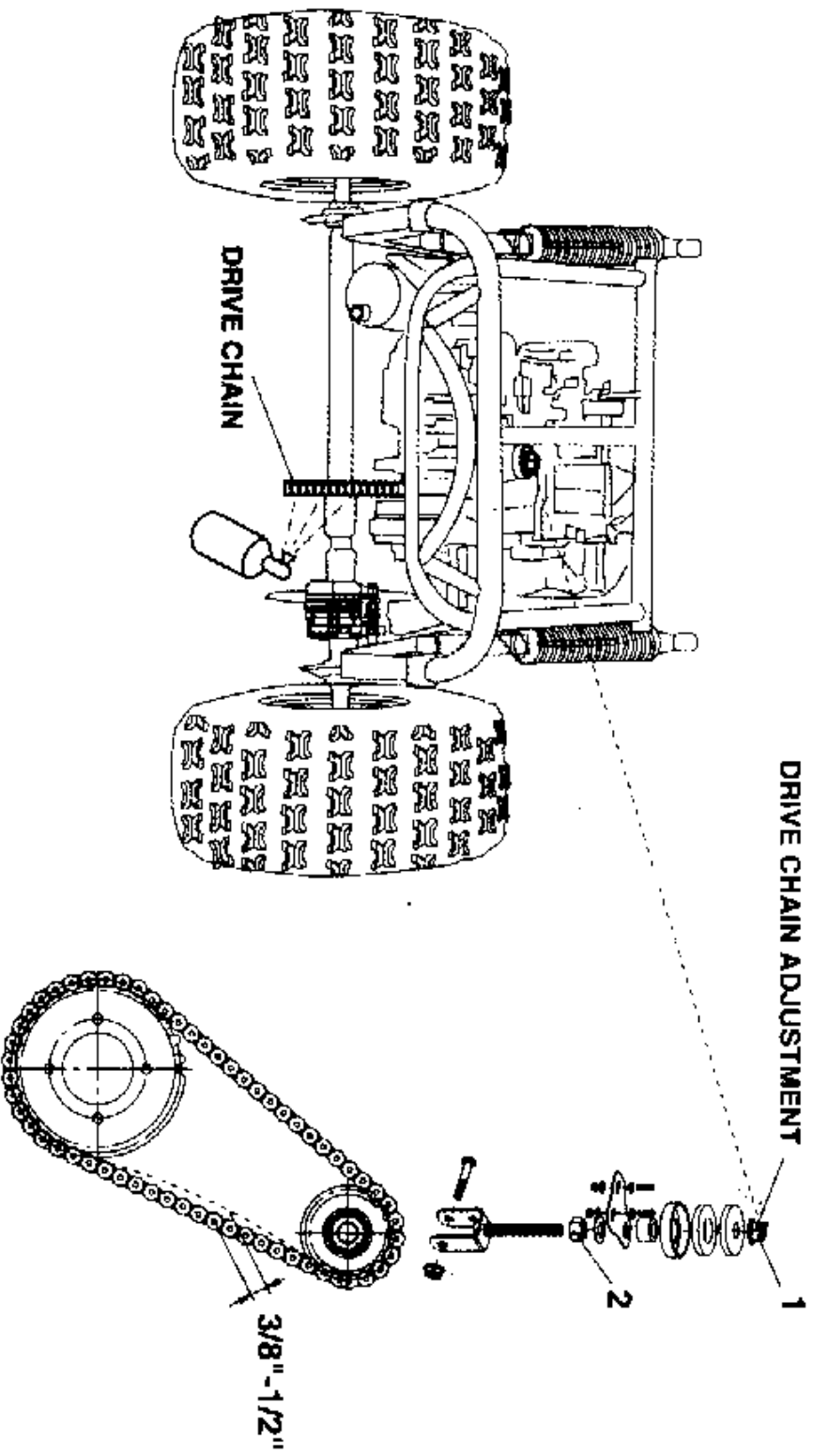

Figure 10

SERVICE INSTRUCTIONS

E. ADJUSTMENT OF FRONT & REAR SHOCK

There're 5 position for you to choose on each shock, the default position would be set by the manufacture in the middle (the third position), See Fig. 11

Please use round nut wrench as you adjusting the position, the tension of shock spring would increase as you left screw and decrease as left screw.

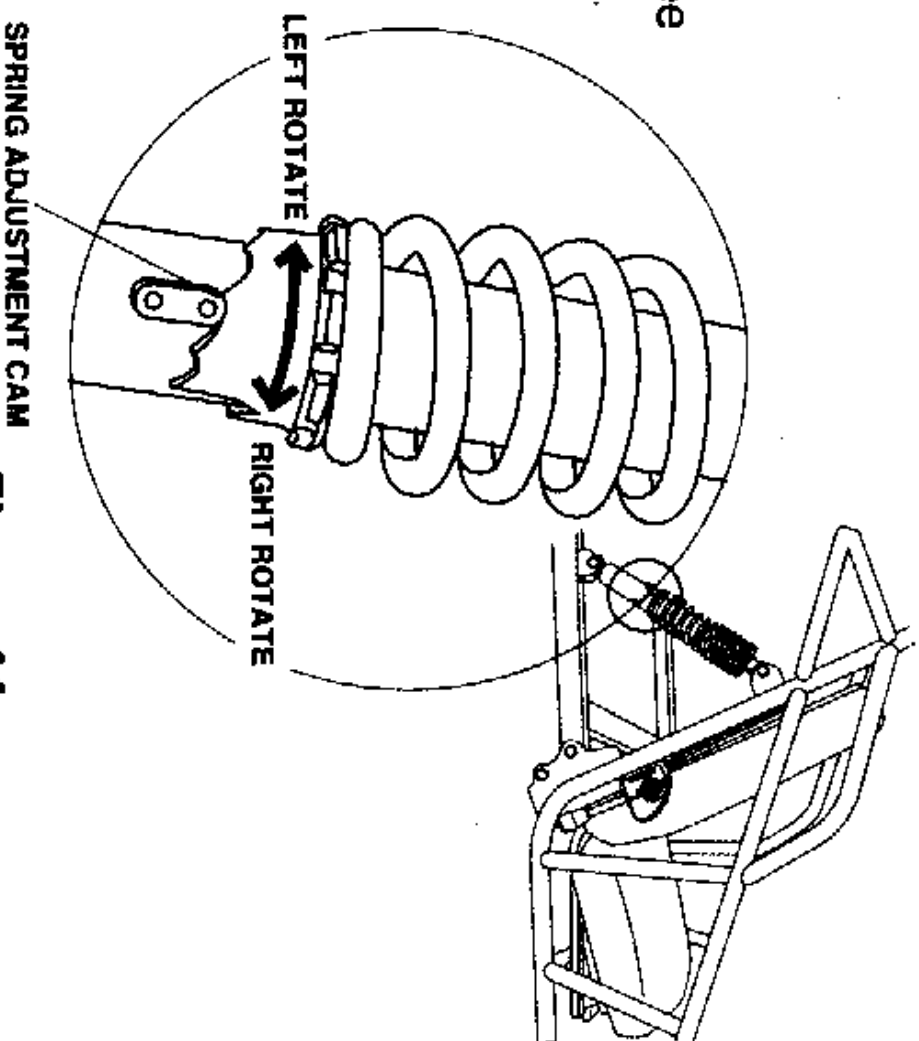

Figure 11

SERVICE INSTRUCTIONS

F. STORAGE INSTRUCTIONS

In the event your kart is not to be operated for periods in excess of 30 days and at the end of each riding season prepare for storage as follows:

DO NOT DRAIN FUEL WHILE ENGINE IS HOT. BE SURE TO MOVE FUN KART OUTSIDE BEFORE DRAINING FUEL.

1. Drain fuel tank and carburetor by allowing engine to run out of fuel. All fuel remaining in the tank must be removed by using a suction device very dangerous, leave out of manual.
2. Lubricate engine cylinder by removing the spark plug and pouring one ounce of clean lubricating oil through the spark plug hole into the cylinder. Crank the engine slowly to spread oil and replace spark plug.
3. Do not save or store gasoline over winter. Using old gasoline, which has deteriorated from storage, will cause hard starting and affect engine performance.

A. FRONT WHEEL REPLACEMENT

DO NOT DISASSEMBLY THE CASTLE NUTS WHEN YOU REPLACE THE FRONT WHEELS. It is only necessary to tighten the nuts so that the wheel turns freely on the axle with minimum end play. (See Fig. 12) Please tighten the nuts after replace the wheels.

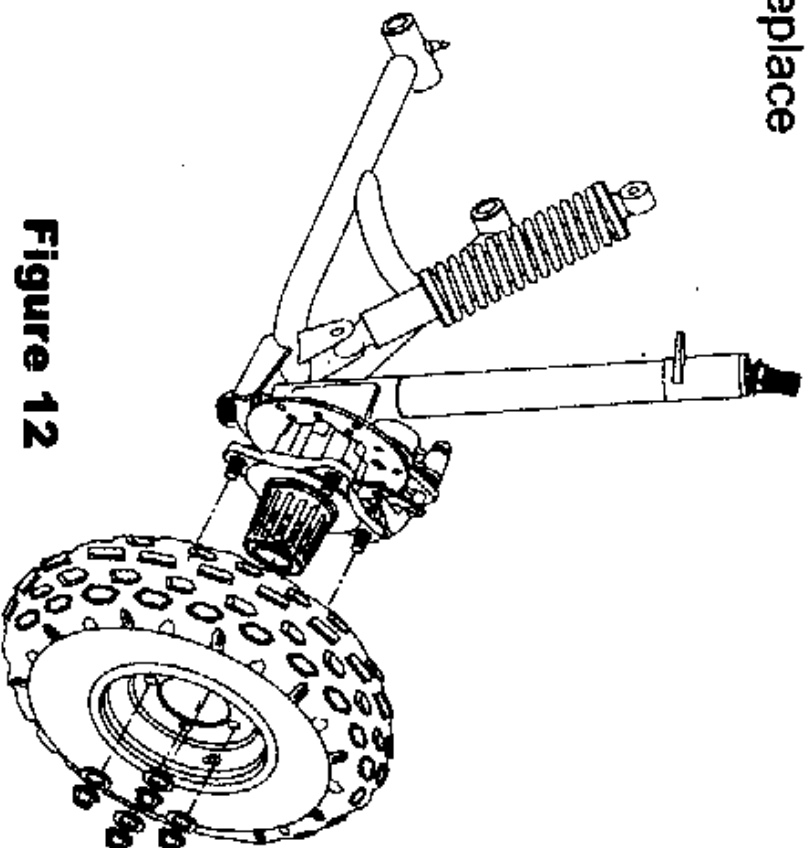
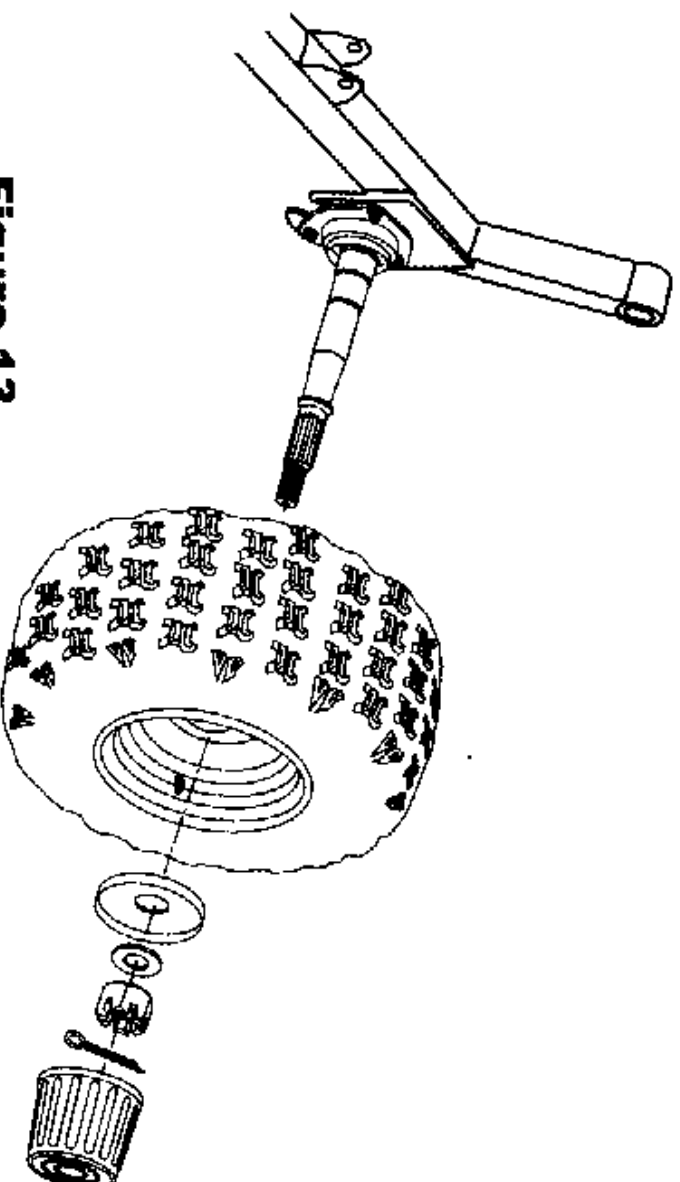

Figure 12

B. REAR WHEEL REPLACEMENT

DO NOT DISASSEMBLY THE CASTLE NUTS WHEN YOU REPLACE THE REAR WHEELS. It is only necessary to tighten the nuts so that the wheel turns freely on the axle with minimum end play. (See Fig. 13) Please tighten the nuts and put on the Dowel Pin after replace the wheels.

**Figure 13**

C. FRONT WHEEL ALIGNMENT

1. The front wheels should be "toed-in" from $1/8"$ to $1/4"$. To check alignment measure distance from A to B(Fig. 14) to the centerline(CL) of the tires with the wheels pointed straight ahead. For the proper toe-in dimension A should be $1/8"$ ~ $1/4"$ greater than dimension B.
2. Loose the lock nuts on both sides of Front Tie Rods. To make Dimension B smaller, screw the rod left turns. If B needs to be longer screw the right turns. Tighten the jam nut tightly against the rod end. Recheck the distance and repeat the above steps until the Dimensions are per paragraph 1 above.

REPAIR

LOCATION OF PARTS

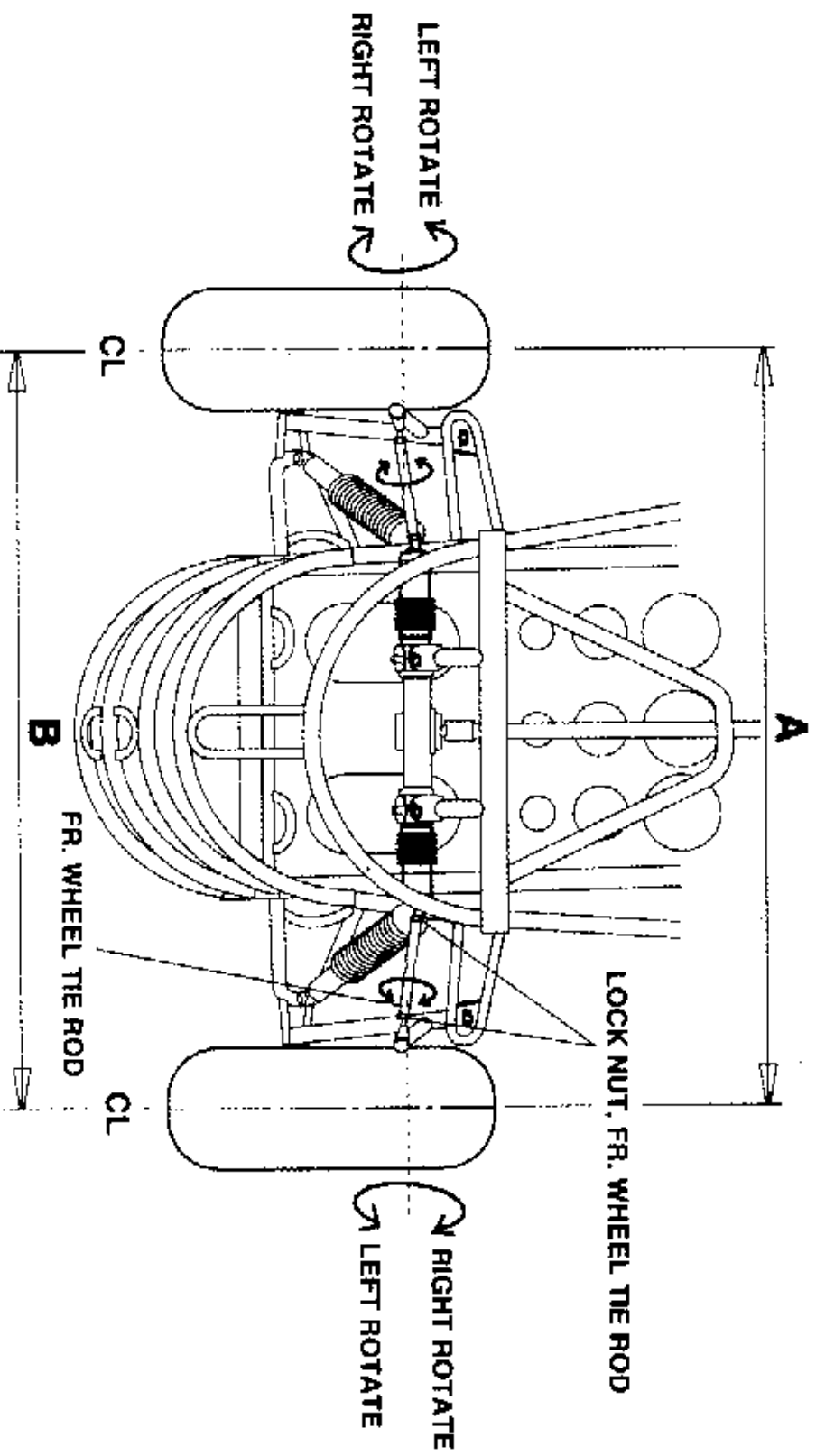

Figure 14

PERIODICAL CHECK AND SERVICES

The maintenance intervals in the following table are based upon average riding conditions. Riding in unusually dusty areas, require more frequent servicing.

Items	Time of service	Initial service (first week)	Monthly	Quarterly	Yearly
Tire pressure/wear		I	I		
Brake performance		I	I		
Tightness of screws		I	I		
Air cleaner				C	I
Carburetor		I	A		C
Spark plug				C, A	
Drive chain		I	I	C, A, L	
Brake oil				I	
Replace gearbox oil			I	R	
Chassis			C, I	L	
Fuel switch/fuel tank			I		C
Battery				I	
Valve clearance of engine				A	

A: adjust C: clean I: inspect, clean or replace if necessary. L: Lubricate R: replace

WIRING DIAGRAM FOR L-M150

